

# Middle Tier Acquisition and Other Rapid Acquisition Pathways

---

Pete Modigliani

Su Chang

Dan Ward

26 Jun 18

Contact us at

[accelerate@mitre.org](mailto:accelerate@mitre.org)



**MITRE**

# Purpose / Outline

---

**To provide an overview of rapid acquisition pathways made available by recent National Defense Authorization Acts (NDAA's)**

- **Section 804 Middle Tier – Rapid Prototyping and Rapid Fielding**
- **Section 806 – Development, Prototyping, Deployment of Weapon System Components**
- **DODI 5000.02 Tailoring and Accelerated Acquisition Model 4**
- **DODI 5000.02 Enclosure 13 Urgent Capability Acquisition**
- **FAR Direction**
- **Service Implementation Direction**

# Rapid Acquisition Pathways

	<b>Section 804 Middle Tier Acquisition</b>	<b>Section 806 Weapon System Component Prototypes</b>	<b>DODI 5000.02 Model 4 Accelerated Acquisition</b>	<b>DODI 5000.02 Enclosure 13 Urgent Capability Acquisition</b>
<b>Summary</b>	Rapid Prototyping and Rapid Fielding	SAE selected most promising prototype	Aggressively tailor when schedule is king	Fulfill urgent operational needs
<b>Requirement</b>	"Approved requirement" Exempt from JCIDS		JCIDS	UON, JUON, or JEON by CCDR or VCJCS
<b>Timelines</b>	Field <5 years; Production start < 6 months	Complete within 2 years	None	Field within 2 years
<b>Funding Limit</b>	None	\$10M or \$50M if Secretary approve	None	Below ACAT I and IA
<b>Other Factors</b>	Exempt from 5000 PM reports to SAE	Budgeted separate from PoR	MDAPs have statutory requirements that limit speed	No JCIDS once initial doc signed

# Section 804 Middle Tier of Acquisition

## Rapid Prototyping

- Use innovative technology to rapidly develop fieldable prototypes to demonstrate new capabilities, meet emerging military needs
- Field a prototype demonstrated in an operational environment
- Residual operational capability within **5 years** of requirement

## Rapid Fielding

- Use proven technologies to field production quantities of new or upgraded systems with minimal development
- Begin production within **6 months**
- Complete fielding within **5 years** of requirement

# Section 804 Overarching Guidance

- **Guidance required shall provide for a streamlined and coordinated requirements, budget, and acquisition process**
  - Develop an approved requirement for each program in a period of not more than **6 months** from the process initiation
  
- **Shall not be subject to JCIDS and DODD 5000.01**
  
- **DoD Rapid Prototyping Fund**
  - For acquisition programs under the rapid prototyping pathway
  - Consist of appropriated funds and those credited by section 828
  - Managed by a senior DoD official designed by AT&L
  - Shall notify the congressional defense committees of all transfers

# 804 Roles for “Defense Streamlined Program”

- **SAE**
  - SAE is MDA (in coordination with AT&L)
  - Shall appoint PM and evaluate PM job performance annually
  
- **Program Manager**
  - Shall report directly to the SAE
  - Authorized to staff positions to manage the program without another organization to the maximum extent practicable
  - Authorized to make cost, schedule, requirements trade-offs in coordination with the users and testers
  - Expeditiously seek Congressional waiver from any statutory or regulatory requirement they determine add little/no value to program

# Potential 804 Rapid Pathways

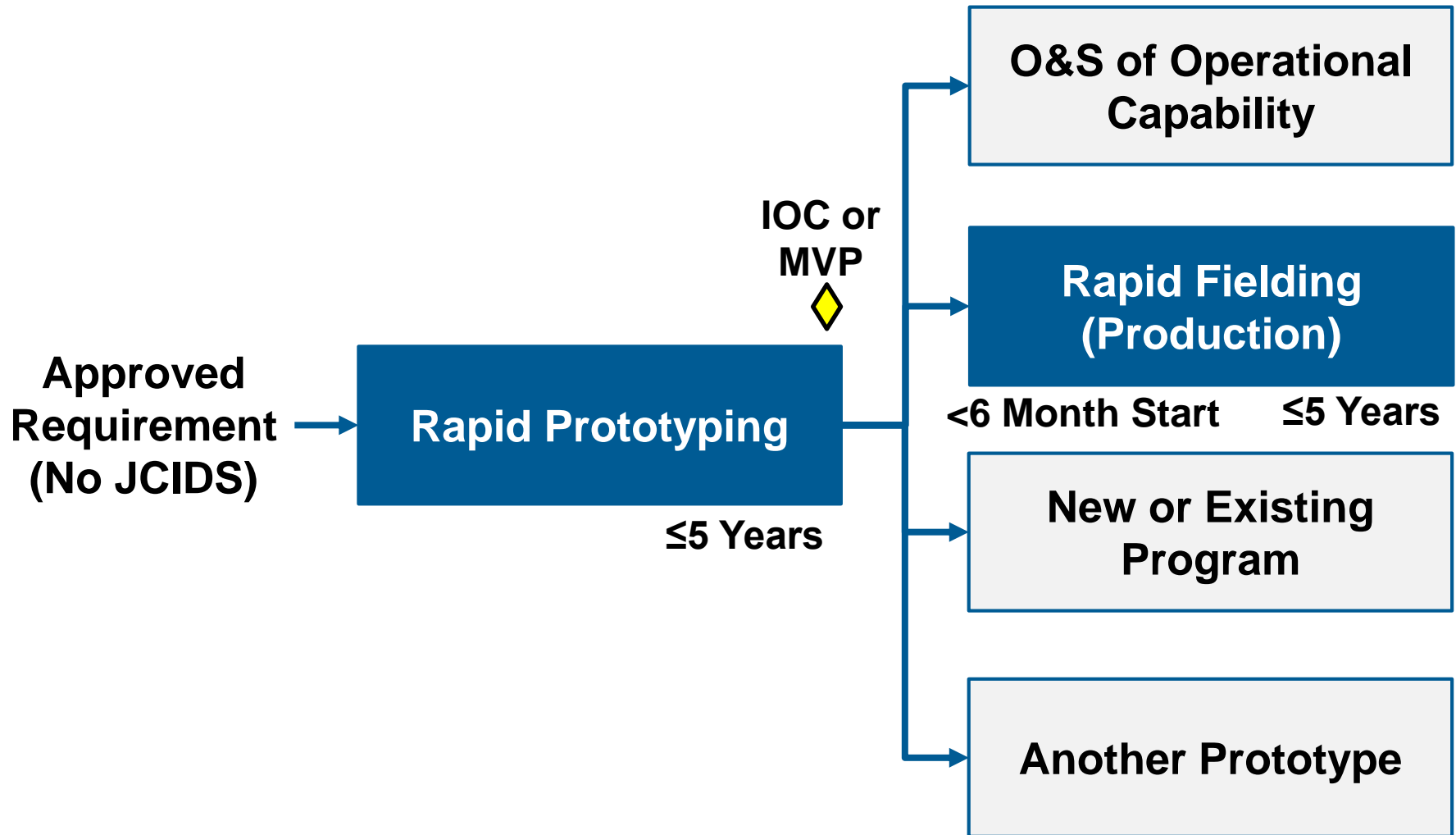

# Traditional Program vs 804 Rapid Program

## Traditional Program

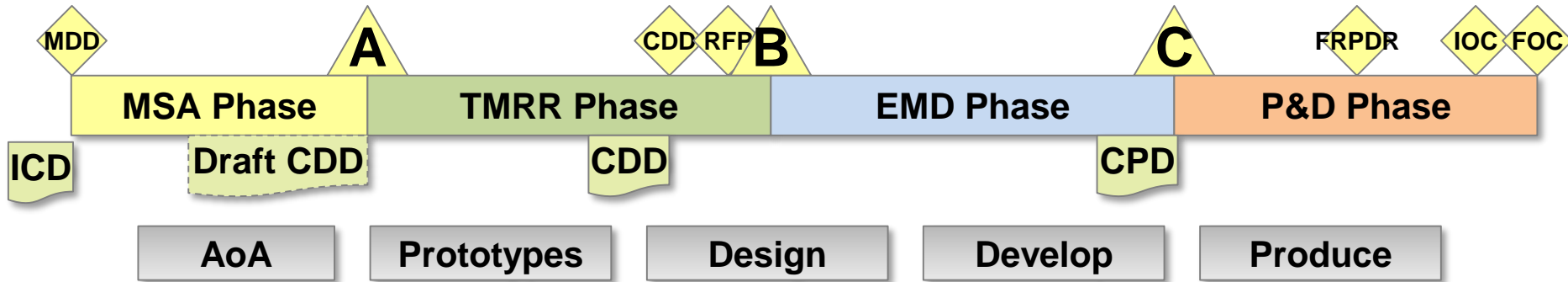

## Section 804 Rapid Program

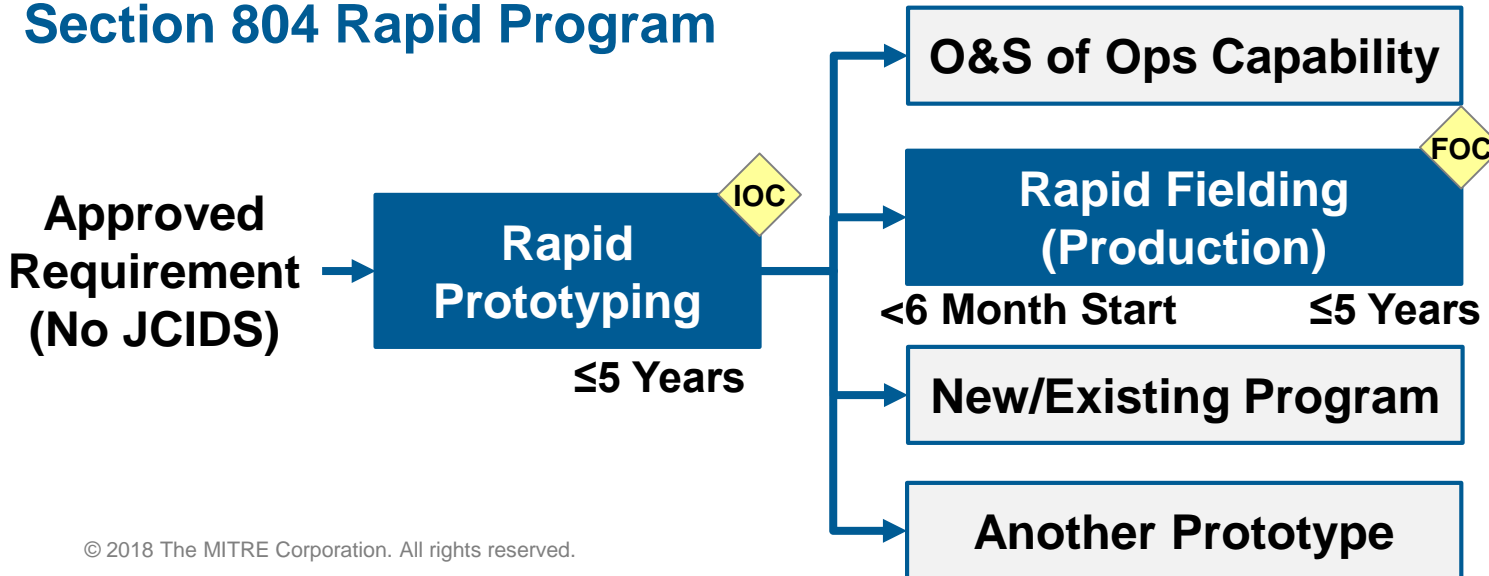



# USD(A&S) Memo on Middle Tier Acquisition

- Ms. Lord provided DoD Components interim authority to implement 804
- Develop rapid prototyping and fielding processes and procedures
- NLT Jan 2019, A&S and Components will collaborate on 804 policy
- Requires collection of key data on programs: name, capability gap, source, funding, dates, result, vendors
- Identify policy changes to enable greater success in implementing 804

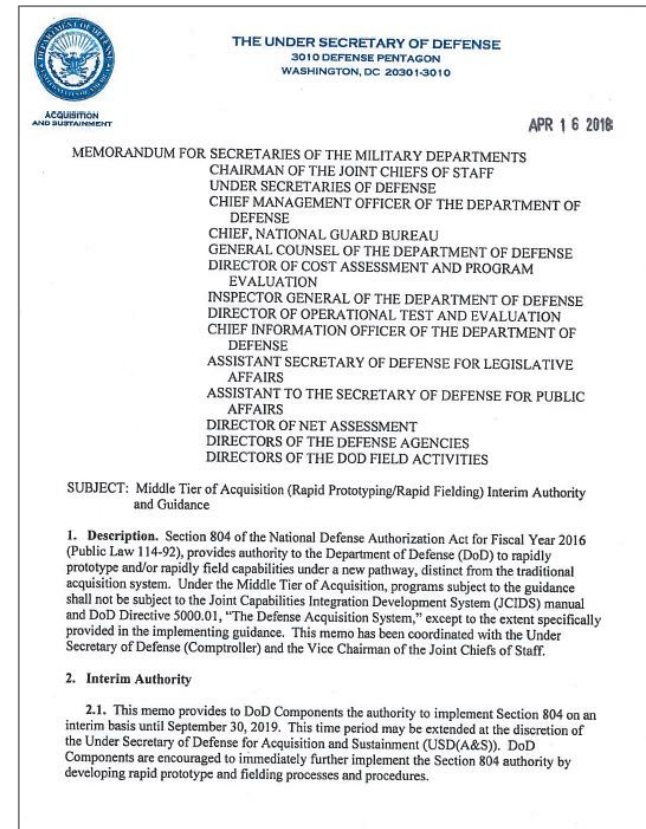

# 806: Development, Prototyping, Deployment of Weapon System Components or Tech (1)

Projects selected by the SAE as being one of the most promising, innovative, and cost-effective prototypes that is expected to be successfully demonstrated in a relevant environment

- **Must be completed within 2 years**
- **Limited to \$10M**
  - Could be funded up to **\$50M** if Secretary approved, Congress notified
- **Prototypes shall be funded through contracts, cooperative agreements, or OTAs**
  - Prototypes can be budgeted separately from a PoR and excluded from MDAP costs
- **Exempt from JCIDS**

# 806: Development, Prototyping, Deployment of Weapon System Components or Tech (2)

- **SAE may select the project for follow-on production contract or OT without competition if**
  - Addresses a high priority warfighter need or reduces the costs of a weapon system
  - Competitive procedures were used for the selection of parties for participation in the original prototype project
  - Participants in the original prototype project successfully completed the requirements of the project; and
  - Prototype of the system to be procured was demonstrated in a relevant environment.
  
- **Each Service Secretary will establish an oversight board or group of senior advisors to manage prototype projects**

# Potential Section 806 Pathways

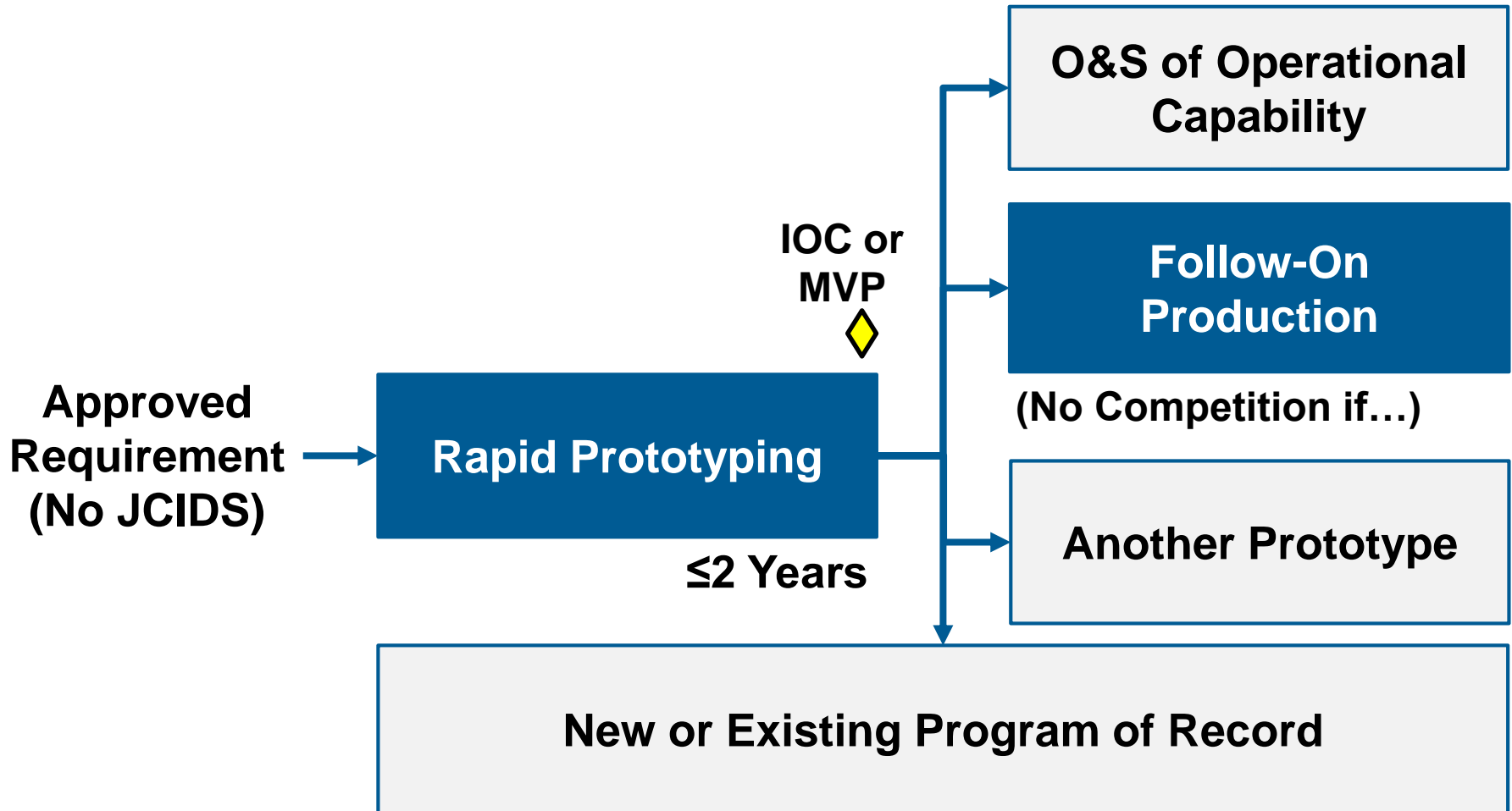

# Acquisition Tailoring in DODI 5000.02

*“The **structure** of a DoD acquisition program and the **procedures** used should be **tailored as much as possible** to the characteristics of the product being acquired, and to the totality of circumstances associated with the program including operational urgency and risk factors.”*

*“MDAs will tailor*

- *program strategies and oversight including*
- *program information*
- *acquisition phase content*
- *timing and scope of decision reviews and decision levels*

*based on the specifics of the product being acquired, including complexity, risk factors, and required timelines to satisfy validated capability requirements ”*

# DODI 5000.02 Model 4: Accelerated Acquisition

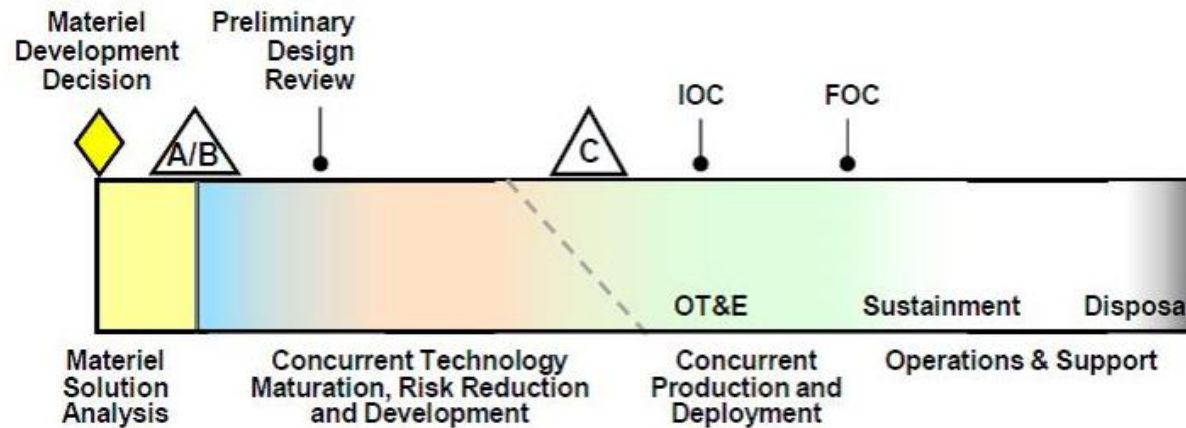

- When schedule considerations dominate over cost and technical risk.
- Compresses or eliminates phases of the process and accepts the potential for inefficiencies in order to deploy capability on a compressed schedule.
- The model shows one example of tailoring for accelerated acquisition and many others are possible.
- This type of structure is used when technological surprise by a potential adversary necessitates a higher-risk acquisition program.

# DODI 5000.02 Enclosure 13

## Urgent Capability Acquisition

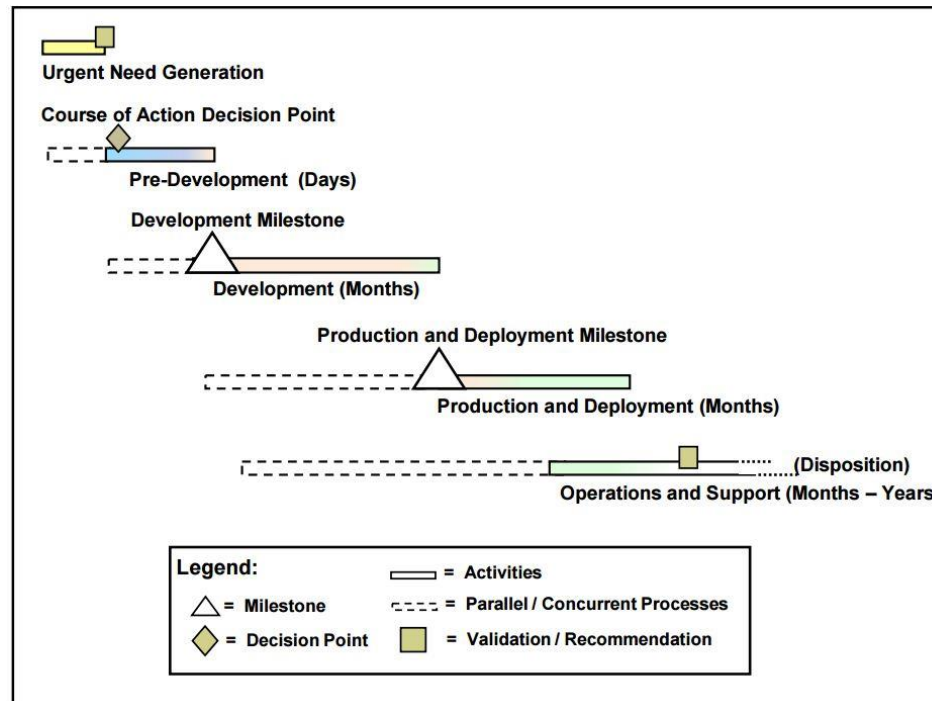

- Provide capabilities to fulfill urgent operational needs and other quick reaction capabilities that can be fielded in **less than 2 years** and are below the cost thresholds of ACAT I and IA programs.
- UON, JUON, JEON
- Exempt from JCIDS

# FAR Direction – Simple

- Agencies shall use simplified acquisition procedures to **the maximum extent practicable** for all purchases of supplies or services not exceeding the simplified acquisition threshold. –[FAR 13.003](#)





# FAR Direction – Innovative

- The System should also, however, **encourage innovation**, and local adaptation where uniformity is not essential. – [FAR 1.102-2\(b\)\(2\)](#)
- The contracting process shall be used to encourage the **best sources** from the scientific and industrial community to become involved... and must provide an environment in which the work can be pursued with reasonable flexibility and **minimum administrative burden**.  
– [FAR 35.002](#)



# FAR Direction – Modular

---

- Modular contracting is intended to **reduce program risk** and to incentivize contractor performance while meeting the government's need for **timely** access to rapidly changing technology...
- Agencies should, **to the maximum extent practicable, use modular contracting** to acquire major systems (see [2.101](#)) of IT.
- Agencies may also use modular contracting to acquire non-major systems of IT. –[FAR 39.103](#)

# Rapid Acquisition Pathways

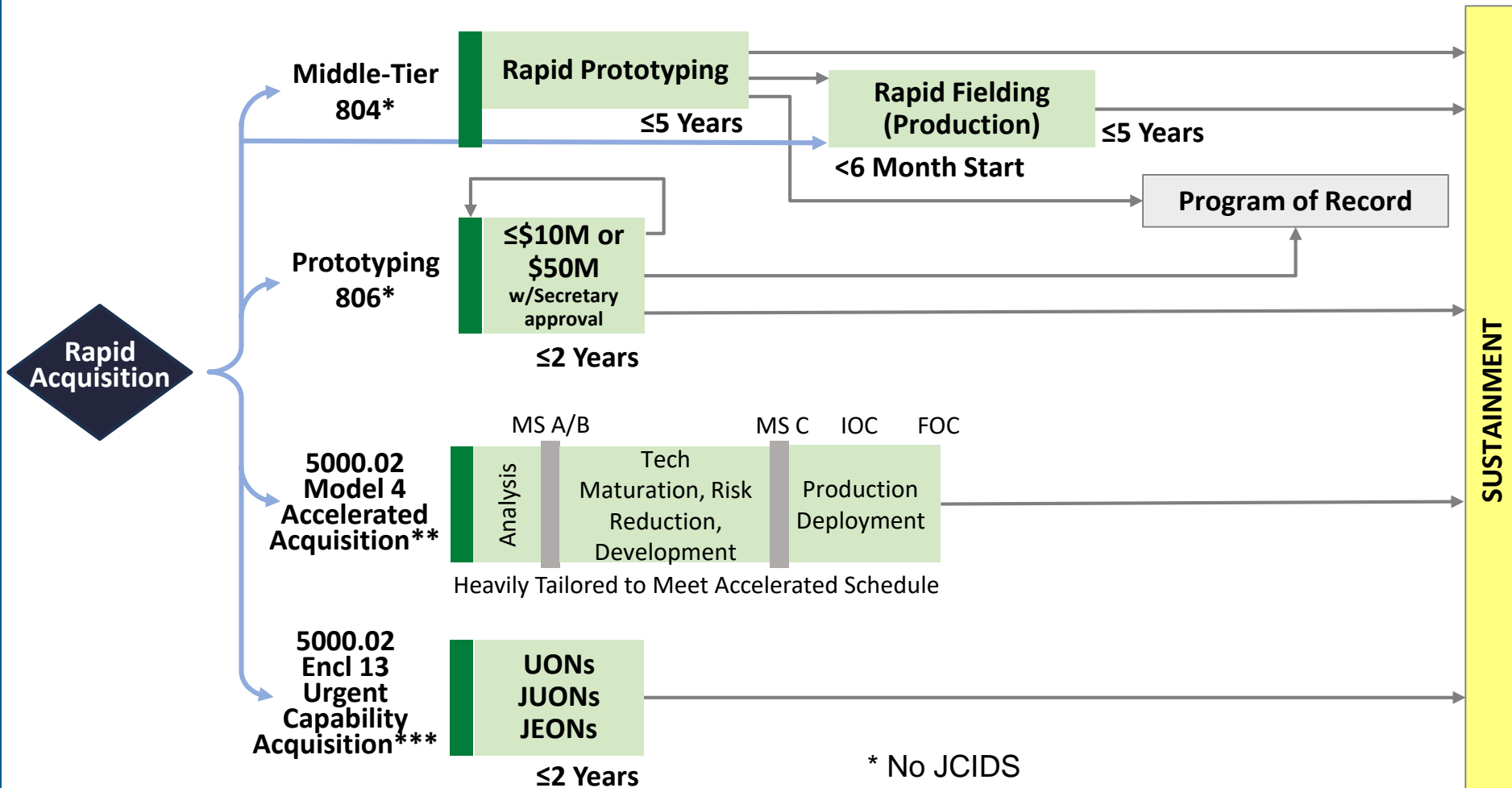

\* No JCIDS

\*\* JCIDS

\*\*\* UON signed by CCDR/VCJCS



# Middle-Tier Acquisition on AiDA

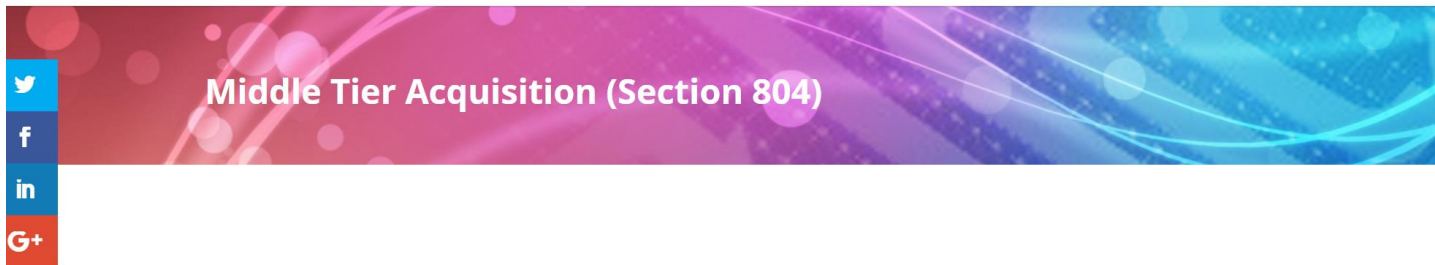

Congress in the FY16 NDAA Section 804 directed USD(AT&L), in consultation with USD Comptroller and VCJCS to establish guidance for a "middle programs that are intended to be completed in a period of 2-5 years via two acquisition pathways:

### Rapid Prototyping

Use innovative technology to rapidly develop fieldable prototypes to demonstrate new capabilities, meet emerging military needs. The objective:

- Field a prototype that can be demonstrated in an operational environment
- Provide for residual operational capability within **5 years** of an approved requirement

### Rapid Fielding

Use proven technologies to field production quantities of new or upgraded systems with minimal development required. The objectives are:

**OSD and Service Implementation policies, legislative language**

<https://aida.mitre.org/middle-tier/>

---

# Air Force Rapid Acquisition

---

# SAF/AQ Guidance Memorandum

- “Contracting officers are encouraged to be **aggressive** using vehicle types, incentives, and penalties to encourage **timeliness**.”
- “Speed through streamlining should be **ferverently pursued...**”
- **Four Tailorable Phases**
  - Alpha: Prototyping
  - Beta: Fielding and Initial Production
  - Gamma: Modernization and Follow-on Production
  - Delta: Operations and Sustainment



DEPARTMENT OF THE AIR FORCE  
WASHINGTON DC

OFFICE OF THE ASSISTANT SECRETARY

AFGM2018-63-146-01

13 June 2018

MEMORANDUM FOR DISTRIBUTION C  
MAJCOMs/FOAs/DRUs

FROM: SAF/AQ  
1060 Air Force Pentagon  
Washington, DC 20330-1060

SUBJECT: Air Force Guidance Memorandum for Rapid Acquisition Activities

By Order of the Secretary of the Air Force, this Air Force Guidance Memorandum immediately establishes guidance for rapid acquisition activities using rapid prototyping and rapid fielding authorities from Section 804 of the National Defense Authorization Act of 2016. **Compliance with this memorandum is mandatory—but hopefully freeing!** To the extent its directions are inconsistent with other Air Force publications, the information herein prevails in accordance with Air Force Instruction (AFI) 33-360, *Publications and Forms Management*.

This guidance applies to military and civilian employees, including the Air Force Reserve and Air National Guard. Ensure that all records created as a result of processes prescribed in this publication are maintained in accordance with Air Force Manual 33-363, *Management of Records*, and disposed of in accordance with Air Force Records Information Management System Records Disposition Schedule. Waiver authorities are addressed in the attachment. This memorandum becomes void after one year has elapsed from its date of publication or upon publication of new instruction permanently establishing this guidance, whichever is earlier.

The authorities addressed in this Air Force Guidance Memorandum put both the reins of programs as well as our reputation in our hands: be dismissive of things that do not matter but very disciplined on things that do. I encourage you to make rapid acquisition our new Air Force standard, not an occasionally used exception. Thus far, we have eight rapid acquisition activities approved or in process, with approximately 25 years of potential schedule acceleration. Now that you have the same authority, I ask each Program Executive Office to track both schedule and delivery acceleration over traditional approaches. Our “Century Challenge” is removing 100 years of total schedule from the Air Force acquisition portfolio; then we will go further. Speed awaits!

William B. Roper, Jr.  
Assistant Secretary of the Air Force  
(Acquisition, Technology & Logistics)

Attachment: Rapid Acquisition Activities Guidance

## [Air Force Guidance Memo for Rapid Acquisition Activities](#)

# Dr. Roper 22 May 18 Email

- 1. Section 804 is now our new standard.**  
Use it wherever allowed unless it doesn't make sense; it usually will.
- 2. We must go over and above to show due diligence.**
- 3. Keep your “requirers” with you throughout prototyping**
- 4. Throw away pens and carry pencils from now on**
- 5. Century Challenge: Keep track of the time you project to save using 804 over traditional acquisition. Goal: Save 100 years**



# SAF/AQ: 7 Steps for Incorporating Rapid Prototyping into Acquisition

---

- 1. Have an aggressive goal**
- 2. Bound your risks**
- 3. Be aggressive but not greedy**
- 4. Constrain time and budget, not the final performance**
- 5. It takes a team to go fast**
- 6. Get a signature from me**
- 7. GO FAST**

[Seven Steps for Incorporating Rapid Prototyping into Acquisition](#)



---

# Naval Rapid Acquisition

---

# Navy Implementation of Section 804

- Hondo memo: [Middle Tier Acquisition and Acquisition Agility Guidance](#)
- The Navy will follow an incremental approach to implementation
  - Enable speed and agility, while maintaining appropriate accountability, oversight, and transparency
  - Collaborate with OSD to better align and evolve policies
  - Series of pilots to exercise these authorities and inform policy
- Directed SYSCOMs and PEOs to assess their contracting, technical, legal, and financial processes to facilitate program **acceleration**
- Rapid Prototyping and Rapid Fielding Documentation
  - Key docs, the elements to address, and approval authorities

<https://news.usni.org/2018/05/10/document-dept-navy-rapid-acquisition-guidance>

# Navy Implementation of Section 804 (2)

Multiple pathways to initiate a rapid prototype

<b>Emergent Strategic Needs</b>	Not documented through the normal Capability Based Assessment process nor sufficient funds programmed through the normal DoD PPBE process
<b>Emergent Technologies</b>	New warfighting capabilities that have been identified as an offsetting or disruptive warfighting need
<b>Documented Needs</b>	Projects that currently have a validated requirement documented via the JROC, JRAC, CNO or CMC Operational Needs process requiring acceleration to meet a warfighting need

<https://news.usni.org/2018/05/10/document-dept-navy-rapid-acquisition-guidance>

# SECNAVINST 5000.42 – Accelerated Acquisition

Dr. Burrow - Dec 2016

## Rapid Prototyping Experimentation and Demonstration (RPED)

- To find a solution for a fleet or force priority needs for which a suitable materiel solution cannot be readily identified.
- Rapidly trials solutions and assesses performance and operational utility.
- Conducts a demonstration and user evaluation ASAP

## Maritime Accelerated Capabilities Office (MACO)

- To accelerate the introduction of advanced warfighting capabilities or fulfill UONs for which there are known requirements and an appropriate materiel solution.
- Programs will result in the fielding of interim or enduring capabilities to mitigate the identified operational gap.

# SECNAVINST 5000.42 – Accelerated Acquisition

- In considering the appropriate accelerated path the Accelerated Acquisition Board of Directors (AA BOD) shall be informed by:
  - Consideration of the operational risk
  - Availability of mature technologies to mitigate the gap
  - Cost and affordability of potential solutions
  - Technical risks of program execution
  
- AA BoD: CNO, CMC, ASN (RD&A) and, as applicable, the DAE
  
- In developing COAs, the DON will seek to leverage mature technology wherever possible
  - The selection will consider innovative solutions from all government, **FFRDCs**, academia, and industry sources.

# Messages from Hondo

- **4Ds**
  - **Decentralize** – Let folks make decisions at the lowest level and hold them accountable
  - **Differentiate** – Think differently from carrier to combat system to AI from development to people implementing solutions
  - **Digitize** – Rethink way we build HW (digital from start), training, production, common combat systems across ships
  - **Develop** – World class talent across enterprise (mil, civ, academia)
  
- **Strength of America is our pivot speed – organizational agility**



# Navy's Geurts on Accelerating Key Programs

- Streamlining requirements and acquisition
  - Empowering team – access to senior decision makes
  - Middle Tier Acquisition – great capability out to the Fleet
- 
- MQ-25 – 2 critical requirements
    - Launch off carrier
    - Refuel aircraft

<https://youtu.be/2E9ae-Cey4g>



---

# BACKUP SLIDES

---



# FY16 NDAA, Section 803

## Expansion of Rapid Acquisition Authority

---

- When SECDEF determines in writing that any **supplies and associated support services** are urgently needed to eliminate a deficiency that have or could result in
  - Combat casualties
  - Critical mission failure
  - Cyber attack
- SECDEF authorizes senior official to **waive any law, policy, directive, or regulation** that would impede the rapid acquisition and deployment of supplies and support services
- Limited to \$200M/year in aggregate
- SECDEF shall notify Congress in 10-15 days
- Any acquisition initiated shall transition to normal acquisition system within 2 years

**Unclear what action if any OSD has taken to implement this**

# FY16 NDAA Section 805

## Use of alternative acquisition paths to acquire critical national security capabilities

- Not later than 180 days after enactment SECDEF shall establish procedures for **alternative acquisition pathways** to acquire **capital assets and services** that meet critical national security needs.
  
- The procedures shall—
  - be separate from existing acquisition procedures
  - be supported by streamlined contracting, budgeting, and requirements processes
  - establish alternative acquisition paths based on the capabilities being bought and the time needed to deploy these capabilities
  - maximize the use of flexible authorities in existing law, regulation

**Unclear what action if any OSD has taken to implement this**

# Non-Traditional and Small Contractor Innovation Prototyping Program (1)

- **SECDEF shall conduct a pilot program for non-traditional defense contractors and small business concerns**
- **Design, develop, and demonstrate innovative prototype military platforms** of significant scope for the purpose of demonstrating new capabilities that could provide alternatives to existing acquisition programs and assets.
- **Authorized to be available \$250M from Rapid Prototyping Fund**
- **Maximize use of**
  - BAAs or other merit-based selection procedures
  - DoD Acquisition Challenge Program authorized by 10 USC 2359b
  - The foreign comparative test program
  - DoD Rapid Innovation Program projects or Phase III agreement of the Small Business Act
  - Streamlined acquisition procedures FY16 NDAA sections 804, 805

**Unclear what action if any OSD has taken to implement this**

# Non-Traditional and Small Contractor Innovation Prototyping Program (2)

- As part of the pilot program, SECDEF shall allocate up to \$50,000,000 on a fixed price contractual basis for FY17 for demonstrations of the following capabilities:
  - Swarming of multiple unmanned air vehicles.
  - Unmanned, modular fixed-wing aircraft that can be rapidly adapted to multiple missions and serve as a fifth generation weapons augmentation platform.
  - Vertical takeoff and landing tiltrotor aircraft.
  - Integration of a directed energy weapon on an air, sea, or ground platform.
  - Swarming of multiple unmanned underwater vehicles.
  - **Commercial small synthetic aperture radar (SAR) satellites with on-board machine learning for automated, realtime feature extraction and predictive analytics.**
  - Active protection system to defend against rocket-propelled grenades and anti-tank missiles.
  - **Defense against hypersonic weapons, including sensors.**
  - Other systems as designated by the Secretary.